

D-TEC

CONTAINERTRAILERS



COMBITRAILER®

one container trailer for
all types of container

The D-TEC Combitrailer® is a divisible semi-trailer, specifically suited to the transport of ISO containers, swap bodies and tank containers. The D-TEC Combitrailer® has registration certificates for the semi-trailer as a whole and for only the front section. This unique concept opens up possibilities for new applications for efficient and multifunctional transportation of virtually all common containers, such as 1x20 ft, 2x20 ft, 1x30 ft, 1x40 ft and high cube 45 ft.

The operating principle of the D-TEC Combitrailer® is based on splitting the trailer between the central twist locks. The front and rear sections are connected by an extending bar. The rear section can be hooked up or unhooked using a locking system. The extending bar can be locked into several positions, including a customs position and a position for 45-foot containers.



 **D-TEC**
CONTAINERTRAILERS





COMBITRAILER®

WWW.CONTAINERTRAILERS.COM



**D-TEC****COMBITRA****COMBITRAILER®****D-TEC**

CONTAINERTRAILERS

Advantages of D-TEC container trailer:

- Simultaneous loading and unloading of two 20-foot containers at the loading platforms
- Unladen weight 7,200 kg (type CT-53-04D) or 8,000 kg (type CT-53-05D)
- Optimum weight distribution: smaller risk of overloading
- Fitted with 11-ton air suspension and 9-ton axles
- Multifunctional use: suitable for virtually all ISO containers, tank containers and swap bodies
- Has 1 or several steering axles

**D-TEC**

CONTAINERTRAILERS

LER®

Options

- 5 axles that make contact with the ground
- support legs at the front end
- rearmost axle as a steering axle
- low tires
- toolbox
- central lubrication
- control panel
- extra high bumper to avoid damage
- 20-ft central connection
- container stops
- extra lift axles
- aluminium wheels (weight saving)



Customs position



Supporting legs at the front end



Lift axles are possible on types CT-53-04D 3x, CT-53-05D and CT-60-05D 4x.

To transport high cube containers, D-TEC can also supply the Combitrailer® with 385/55 R22.5 tires. This lowers the loading floor height by 8 cm (from 120 cm to 112 cm) without affecting the payload capacity.



Locking plastic toolbox



Central grease lubrication

D-TEC

CONTAINERTRAILERS



Steering axle only possible on types CT-53-04D, CT-53-05D and CT-60-05D.



Alcoa aluminium wheels. Weight saving of 200 kg on 4-axle configuration and 250 kg on 5-axle configuration.



D-TEC

COMBITRAILER®

WWW.CONTAINERTRAILERS.COM



control lift axle

The builders of multifunctional container trailers

innovations

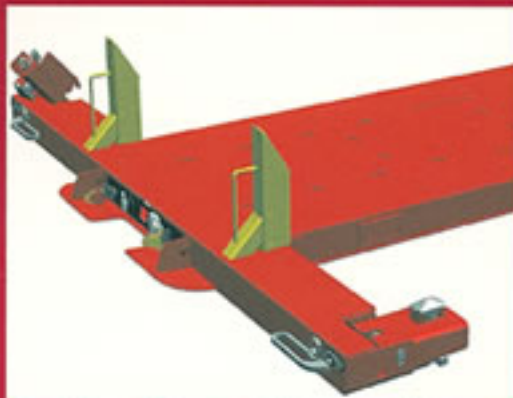

New flip-over beam (weight saving 45 kg).
Front end unloading possibility.
Easier to use.



New, easier to operate dashboard
(tilted an extra 15 degrees).

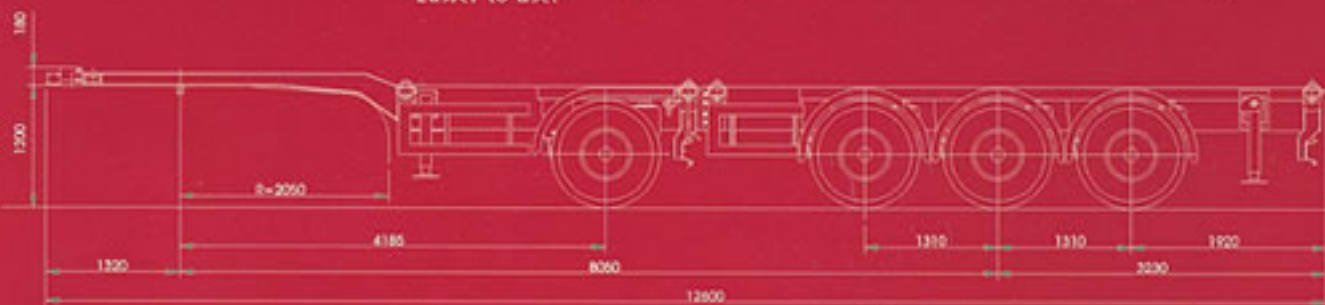

Type CT-53-04D

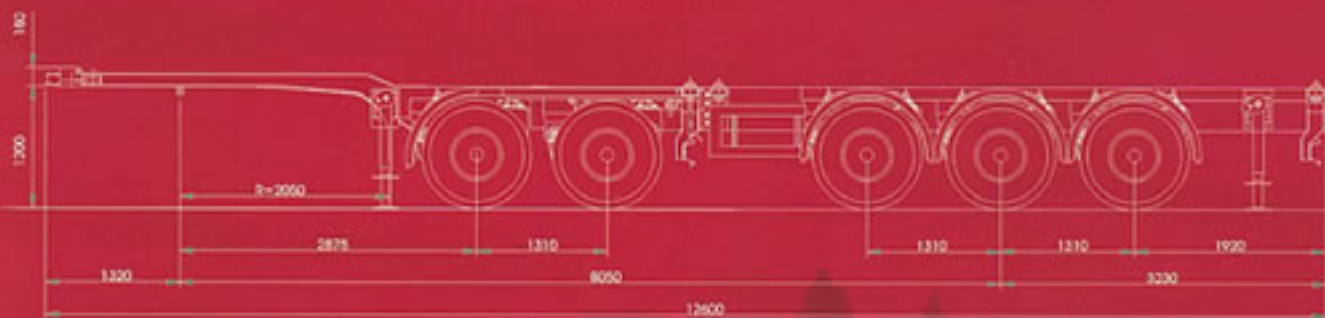

Type CT-60-05D

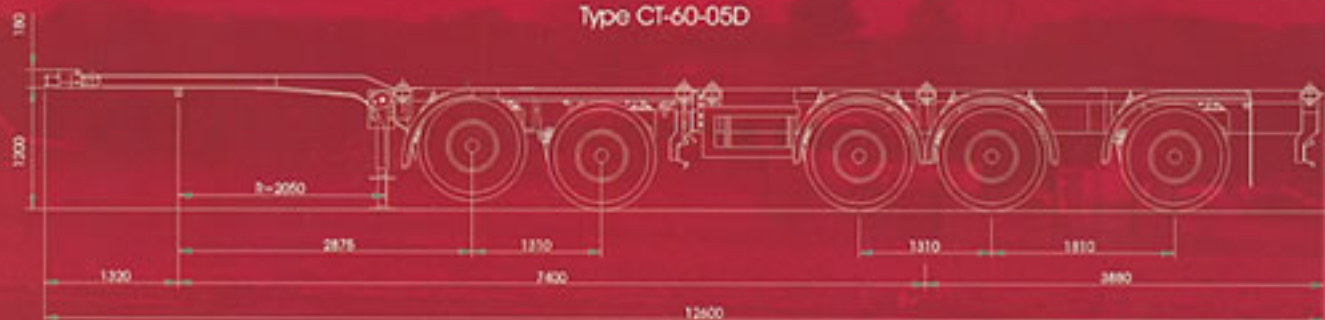

Type CT-53-04/5D and CT-60-05D (with extra steering axle)

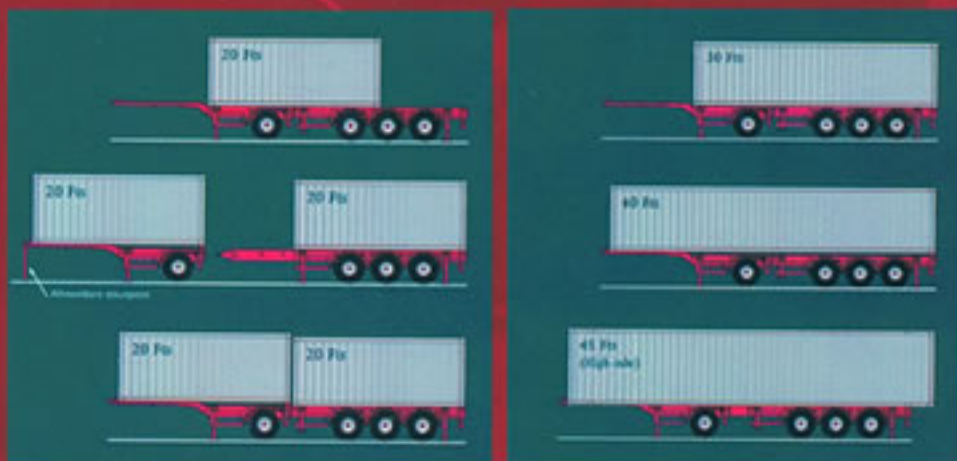

all load types

D-TEC

CONTAINER TRAILERS



COMBITRAILER®

one container trailer for all situations

When transporting two 20-foot containers on a standard container chassis the door position of the front container always poses a problem, making it impossible to load or unload both 20-foot containers at unloading platforms and dock shelters. A tractor-trailer unit does offer this possibility, but has the major disadvantage of only being able to transport 20-foot containers. This makes the D-TEC Combitrailer® the right and most effective alternative, allowing you to simultaneously load or unload two 20-foot containers at loading platforms or dock shelters, and to transport virtually all standard types of container.

You can also decide to leave the rear part of the semi-trailer on the unloading location and continue to your next unloading location with the front section. If you regularly transport 20-foot containers, the D-TEC Combitrailer® offers you the highest return, since it enables you to minimize your waiting times, whereas the combined trips can considerably increase your daily returns.



 **D-TEC**
CONTAINER TRAILERS



D-TEC

CONTAINERTRAILERS



The builders of multifunctional container trailers

The Combitrailer® and Flexitrailer® have made D-TEC into the undisputed European market leader. In order to reinforce this leading position, D-TEC makes significant investments in innovative technology and continuous improvements of its quality and service. D-TEC has received European Engineering Awards for two of its innovative products.

The multifunctional D-TEC container trailers, the D-TEC Combitrailer® (divisible container trailer) and the D-TEC Flexitrailer® (extending container trailer), are the result of the same combination of advanced technology and tried-and-tested expertise that have allowed D-TEC to create its unrivalled vehicles. These trailers owe their reliability and quality to such aspects as the highly advanced production process, where a fully automatic, computer-controlled welding process ensures welded connections of an unparalleled, consistently high quality.

The multifunctional D-TEC container trailers guarantee their users optimum availability combined with the maximum possible cost efficiency. This is recognised by a growing number of transport companies throughout Europe who exclusively invest in D-TEC container trailers when expanding or replacing their vehicle fleet.



Your dealer for container trailers:

 **D-TEC** DISTRIBUTIE NEDERLAND

 **D-TEC**
CONTAINERTRAILERS

WWW.CONTAINERTRAILERS.COM

D-TEC CONTAINERTRAILERS B.V.
NOBELWEG 3
6669 MV DODEWAARD
THE NETHERLANDS
TEL. +31 488 410864
FAX +31 488 483017
WWW.CONTAINERTRAILERS.COM

subject to version changes